

VITALink[®] Armored 2 Hour Fire Resistive Circuit Integrity Cable with Hose Stream

INSTALLATION GUIDE
For 14 AWG Armored
2 Hour Fire Resistive Applications



UL 105°C Listed Type FPLR-LS, CL3R-LS
CSA FAS105 ST1 FT4
Armored
For use in Electrical Circuit Integrity
System FHIT.40B & FHIT7.40B
R27557, (72v)



Installation Guide Dated September 2018

Table of Contents

SCOPE	1
INTRODUCTION	1
ELECTRICAL CIRCUIT INTEGRITY SYSTEM FHIT.40B	1
DESIGN/SYSTEM/CONSTRUCTION/ASSEMBLY USAGE DISCLAIMER	3
TOOLS REQUIRED FOR TERMINATION	4
PULLING CALCULATIONS	4
Maximum Allowable Pulling Tension	5
Back Tension	6
BEND RADIUS CALCULATIONS.....	7
INSTALLATION DETAILS	8
1. CABLE SUPPORT	8
2. WALL OR FLOOR ASSEMBLY:	9
3. FIRE RESISTIVE CABLE:	9
4. SUPPORTS:.....	9
5. SNAKE TRAY [®] SUPPORTS FOR HORIZONTAL INSTALLATION ONLY:.....	11
6. ADDITIONAL INFORMATION:	14
7. JACKET REMOVAL (when provided)	15

SCOPE

VITALink[®] Armored 2-Hour Fire Resistive Circuit Integrity Cable is a unique cable which offers superior fire endurance capabilities along with the well-established benefits & features associated with NEC Type FPLR-LS, CL3R-LS cable designs. This cable is specifically designed to meet the circuit integrity requirements in NFPA 72 National Fire Alarm and Signaling Code, as well as other low voltage critical circuits in NFPA 70 National Electrical Code.

INTRODUCTION

The following instructions are for the VITALink[®] Armored 2-Hour Fire Resistive Circuit Integrity Cables for UL 2196 and ULC S139 Electrical Circuit Integrity System No. FHIT.40B & FHIT7.40B, with Hose Stream Test. The National Electrical Code, Canadian Electrical Code, and all applicable rules and regulations, including federal, state, or provincial, local, and, municipal or territorial laws should be followed.

ELECTRICAL CIRCUIT INTEGRITY SYSTEM FHIT.40B and FHIT7.40B

Electrical Circuit Integrity Systems consist of components and materials that are intended to provide protection for specific fire alarm and control wiring systems with respect to the circuit integrity upon exterior fire exposure. The specifications for Electrical Circuit Integrity System No. FHIT.40B and FHIT7.40B and its assembly are all important details in the development of the ratings.

Ratings apply only to the entire integrity system assembly, constructed using the combination of components specified in the system. Individual components and materials are designated for use in a specific system(s) for which corresponding ratings have been developed, and are not intended to be interchanged between systems. Ratings are not assigned to individual system components or materials.

The Electrical Circuit Integrity System No. FHIT.40B and FHIT7.40B must be fastened to a concrete or masonry wall or a concrete floor-ceiling assembly. The fire rating of wall or floor-ceiling assembly must be equal to or greater than the rating of the electrical circuit integrity system. This is to ensure that the complete electrical circuit integrity system will survive during the fire and hose stream exposure.

The Electrical Circuit Integrity System No. FHIT.40B and FHIT7.40B is evaluated by the fire exposure and water hose stream test as described in the Standards ANSI/UL 2196 and CAN/ULC-S139. The system contains the construction details of the tested configuration. The conductor size, cable type, and voltage rating, etc. are construction details that are also provided. Cables are listed to NEC and CEC Types and constructed to:

- UL - Type FPLR-LS to UL 1424, CL3R-LS to UL 13
- CSA – FAS105 ST1 to C22.2 No. 208

The Electrical Circuit Integrity System No. FHIT.40B and FHIT7.40B was tested with both steel-strut supports and with stainless steel Snake Tray cable support system. The hardware, clamps, strut, etc., unless otherwise noted, are to be made of steel so that these components do not melt in fire. No substitution to the equipment listed in the system is allowed.

The supports are an important part of The Electrical Circuit Integrity Systems No. FHIT.40B and FHIT7.40B, with Hose Stream Test. The maximum distance between the supports is listed in the system and should not be exceeded. The type of support and the distance between the steel supports is unique to that specific system and is for all sizes/types of cable unless otherwise noted in a specific system.

The VITALink[®] Armored Cable was tested in both horizontal with offsets configurations and vertical configurations and the support mechanisms are detailed in the system.

Compatibility of support materials used in Electrical Circuit Integrity System No. FHIT.40B and FHIT7.40B is also a concern. Bare copper should not be in contact with hot dip galvanized cable tray or supports.

These systems shall be installed in accordance with all provisions of the National Electric Code and/or the Canadian Electric Code, as applicable to location, and as amended by the details of each individual system (such as type of supports and distance between supports).



NOTE: Authorities having jurisdiction should be consulted in all cases as to the specific requirements covering the installation and use of these classified systems.

The following instructions are for the VITALink[®] Armored 2-Hour Electrical Circuit Integrity System No. FHIT.40B and FHIT7.40B. These requirements must be followed to maintain the 2-Hour rating in a fire rated area. It is assumed that the cable has been properly sized and the installation properly designed. Comtran Engineering support should be contacted for questions not addressed in the instructions.

DESIGN/SYSTEM/CONSTRUCTION/ASSEMBLY USAGE DISCLAIMER

- Authorities Having Jurisdiction (AHJ) should be consulted prior to construction and in all cases as to the particular requirements covering the installation and use of UL Certified products, equipment, system, devices, and materials.
- Fire resistance assemblies and products are developed by the design submitter and have been investigated by UL for compliance with applicable requirements. The published information cannot always address every construction nuance encountered in the field.
- When field issues arise, it is recommended the first contact for assistance be the technical service staff provided by the product manufacturer noted for the design. Users of fire resistance assemblies are advised to consult the general Guide Information for each product category and each group of assemblies.
- Only products which bear UL/CSA Marks are considered Certified.

The following cables are approved for use in Electrical Circuit Integrity System No. FHIT.40B and FHIT7.40B.

Part Number	Number of Conductors	Nominal Core Diameter (in/mm)	Nominal Armor Diameter (in/mm)	Nominal Cable Diameter over Outer Jacket (in/mm)	Approximate Net Weight (Lbs/1000 Ft)
No Overall Jacket - FPLR-LS/CL3R-LS/FAS105 ST1 FT4					
36516	2	0.334/8.484	0.620/15.748	NA	264
36517	4	0.504/12.802	0.840/21.336	NA	447
36518	6	0.538/13.665	0.880/22.352	NA	506
36519	8	0.605/15.367	0.920/23.368	NA	589
With Overall Jacket - FPLR-LS/CL3R-LS/FAS105 ST1 FT4					
36520	2	0.334/8.484	0.620/15.748	0.684/17.374	306
36521	4	0.504/12.802	0.840/21.336	0.934/23.724	532
36522	6	0.538/13.665	0.880/22.352	0.974/24.740	601
36523	8	0.605/15.367	0.920/23.368	1.024/26.100	682

TOOLS REQUIRED FOR TERMINATION



PULLING CALCULATIONS

When installing the cable, the maximum pulling tension on the conductors and on the full cable should not be exceeded. When the cable is pulled around a bend, it is in contact against the inner arc of curvature of the bend. If any substantial amount of pulling force has been developed in the cable, the friction load due to the pressure at this point will greatly surpass that due solely to the weight of the cable. Thus, bends in the run increase the pulling load significantly. Factors that shall be considered prior to installation, to minimize the possibility of cable damage, are as follows:

- Tensile strength of the conductors
- Method of attachment to the cable
- Sidewall pressure
- Estimated pulling tension
- Force required to pull the cable off the reel
- Coefficient of friction between the cable and adjacent surfaces
- Bend radius

Maximum Allowable Pulling Tension

The maximum allowable pulling tension on the cable(s) is the lesser of the maximum allowable tension based on conductor strength, the maximum allowable tension based on sidewall pressure, and the limit based on the attachment method to the cable.

Max Pull Strength	Value in lbs.
2 Conductor	66
4 Conductor	131
6 Conductor	197
8 Conductor	263

*see IEEE 1185 for additional information on Pulling Calculations.

Cable Attachment Limit

When attaching to the cable it is important to apply equal tensions to the conductors and the armor simultaneously. The attachment methods and/or ropes used to pull the cable must be rated for the applied force. Do not exceed the maximum pulling tensions.

Sidewall Pressure

When a cable is pulled around a bend, radial force is exerted on the insulation, armor, and jacket as the cable is pressed against the inner arc of the bend. This is referred to as sidewall pressure and is expressed as pounds per foot of radius.

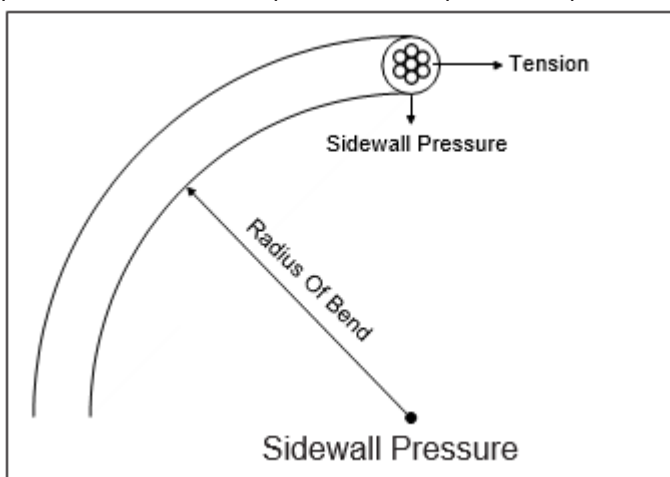

Sidewall pressure is important in cable pulling calculations for two reasons. The first is its increase in the total pulling tension due to greater pressure between the cable and the bend. The second is its crushing effect upon the cable insulation and the possibility of permanent damage to the insulation and/or the cable armor if excessive sidewall pressures are permitted. Sidewall pressure is usually the determining factor when establishing maximum allowable pulling tension for large conductor sizes.

The maximum value for sidewall pressure depends on the cable design. For VITALink[®] Armored it is normally 400 pounds per foot of bend, with a 10-times pulling radius multiplier. Under certain circumstances it may be necessary to reduce the bend radius multiplier to 7 times (which is provided for permanent training). For this case, the sidewall pressure should not exceed 300 pounds per foot of bend.

Back Tension

The force required to pull a cable off the reel is generally referred to as back tension. This is normally taken to be zero, since the cable is fed off the reel. This value may be negative, and light braking may be applied to control the flow of cable to avoid feeding at too great a rate. For downward pulls, considerable braking may be required.

BEND RADIUS CALCULATIONS

In establishing the minimum allowable bend radius for a cable, one must consider that two distinct cases occur. There are bends which occur during pulling (in which case the cable is under tension and is subsequently straightened after leaving the bend) and a bend made as part of the permanent training in position (in which case the cable is not under tension and is usually only bent once). Obviously, for pulling cable under tension, the radius should be as large as practical to minimize the danger of flattening the armor or other damage occurring. For permanent training, when no subsequent straightening or re-bending is required, the minimum allowable radius can be smaller. Guidelines for the minimum permissible radius of bend have been established for these conditions:

- 1) The **minimum training radius**, is used where no tension is applied to the cable (i.e., permanent training), and
- 2) The **minimum pulling radius**, is used where tension is applied to the cable.

Values recommended for bend radii are provided in the following tables.

Note, bend radius is measured from the inside portion of the cable.

VITALink[®] Armored with Jacket — Minimum Bend Radius of Cable

No. of Conductors	Conductor Size (AWG/Kcmil)	Normal Armor Diameter (Inches)	Min. Bend Radius (Inches)	
			Training	Pulling
2	14	0.684	4.8	6.8
4	14	0.934	6.5	9.3
6	14	0.974	6.8	9.7
8	14	1.014	7.1	10.0

VITALink[®] Armored — Minimum Bend Radius of Cable

No. of Conductors	Conductor Size (AWG/Kcmil)	Normal Armor Diameter (Inches)	Min. Bend Radius (Inches)	
			Training	Pulling
2	14	0.620	4.3	6.2
4	14	0.840	5.8	8.4
6	14	0.880	6.1	8.8
8	14	0.920	6.4	9.2

INSTALLATION DETAILS

1. CABLE SUPPORT

For cables installed in non-fire rated areas install per the NEC or CEC. For cables installed in fire rated areas, see limits for UL System 40B.

When transitioning from a straight run of VITALink[®] Armored cable to a bend, use additional supports at the start of the bend and the end of the bend as shown below.

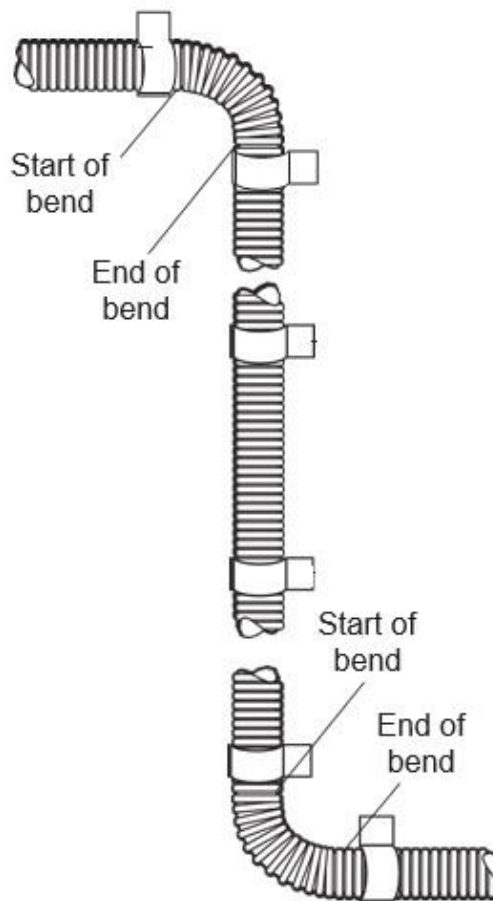

For VITALink[®] Armored cables, cable shall be secured within 12 inches of boxes, cabinets, fittings or other cable terminations. It is recommended that support systems be completed as soon as possible after the cable is installed. Fasten the cable at the far end of the installation and work back toward the reel, straightening as you go. Straighten by hand if possible, do not use tools such as a hammer or screwdriver, since this may deform the armor. Although not required, forms made from preformed PVC conduit bends cut in half may be used as a guide when forming bends. Make sure the minimum bend radius is observed.

Bend in small increments, do not try to make the entire bend in one operation, shape into final position gradually. When bending multiple cables at the same place, shape the inner cable and form the other cables to this one. This will provide uniform curves. Do not leave long lengths of cable in a manner that will subject cable to point stresses. If a long length of cable is left hanging unsupported, the cable may be damaged before connection is completed.

Cables should not be held under tension after installation and some slack is desirable in the region of the terminations. In open installations, the cable must be adequately supported to prevent undue strain on the cable and the termination.

2. WALL OR FLOOR ASSEMBLY:

Minimum 2 hour rated concrete or masonry wall or concrete floor. Opening in wall or floor through which raceway passes is to be sized to closely follow the contour of the raceway. Through opening in wall or floor shall be fire stopped using an approved firestop system. See Through-penetration Firestop Systems (XHEZ) for presently certified firestop systems.

3. FIRE RESISTIVE CABLE:

The 2-hour fire rating applies to Armored cable passing completely through a fire zone and terminating a minimum of 12 inches beyond the fire rated wall or floor bounding the fire zone. The cables, as identified below, may be installed in the vertical or horizontal orientation.

COMTRAN CABLE LLC - VITALink[®] Brand Type FPLR-LS/CL3R-LS & FAS105 Armored Cables with or without an Overall Jacket. To be installed as described herein and in accordance with the manufacturer's installation instructions dated September 2018.

4. SUPPORTS:

Supports - Min 12 gauge, by 1-1/2-inch-wide or 1-5/8-inch-wide, painted or unpainted, slotted steel channels with hemmed flange edges. Channel bottom with or without holes. Lengths of slotted steel channels 5 feet and less shall be secured to the wall or floor with a min of two 1/4-inch diameter (or larger) by 2-1/4-inch min long concrete screws, or 1/4-inch diameter (or larger) by 1-3/4-inch-long min steel masonry anchors. One screw or anchor to be located at each end of the slotted steel channel. Lengths of slotted steel channel in excess of 5 feet require a min of three screws or anchors, one at each end of the channel and one centrally located within the length of the channel.

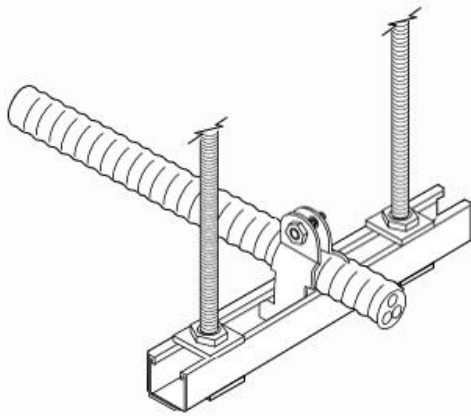

A. Trapeze-type Supports – When the cable is installed on/from trapeze-type supports, the trapeze-type supports shall be secured from the surface of the floor. The supports shall be spaced a maximum of 4 feet on center.

B. Clamps – For armored jacketed VITALink[®] cables, both vertical and horizontal installations, Kindorf[®] J-800 series interlocking strap with Kindorf[®] J-851 locking brackets shall be used (Figure 2). The inside diameter of each interlocking strap shall be sized to correspond with the outside diameter of the cable, to provide a secure mount with the strap of the clamp in complete contact with the outside of the cable.

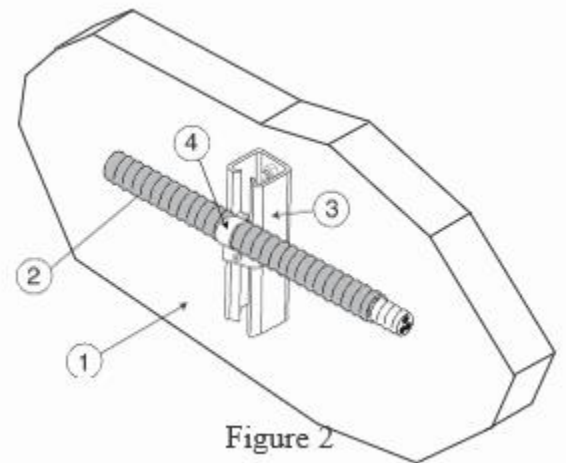

Figure 2

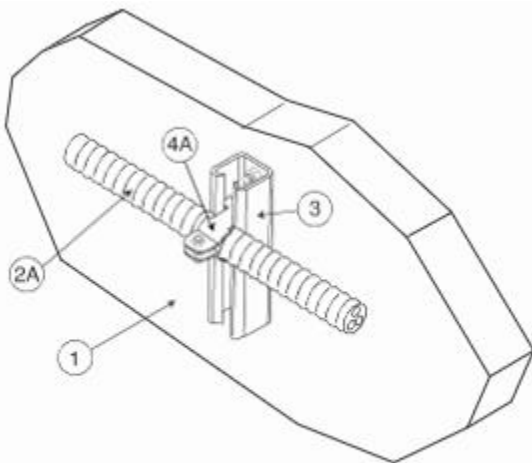

Figure 3

B2. Clamps – In lieu of item B only for VITALink[®] Type Armored cable without an outer jacket, in both vertical and horizontal installations, a two-piece single bolt type pipe clamp, or one piece, saddle type pipe clamps (not shown), sized to correspond with the outside diameter of the cable (Figure 3). The clamp shall provide a secure mount to the strut without deforming the copper armor.



NOTE: For vertical cable installations, the supports shall be spaced a maximum of 6 feet on center. For horizontal cable installations using steel struts, the supports shall be spaced a maximum of 4 feet on center.

5. SNAKE TRAY[®] SUPPORTS FOR HORIZONTAL INSTALLATION ONLY:

Both Jacketed or Unjacketed Armored Cables can be installed in the horizontal orientation via Snake Tray 505 Series as follows:

Determine the cable pathway layout. The Snake Tray[®] shall be secured to the wall surface using 1/4-inch diameter (or larger) by 2 1/4-inch min long concrete screws, or 1/4-inch diameter (or larger) by 1 3/4-inch-long min steel masonry wedge anchors inserted through cable system Stainless Steel Retention plates, RP-12-SS316. The distance between support mounts is a maximum of 5 feet.

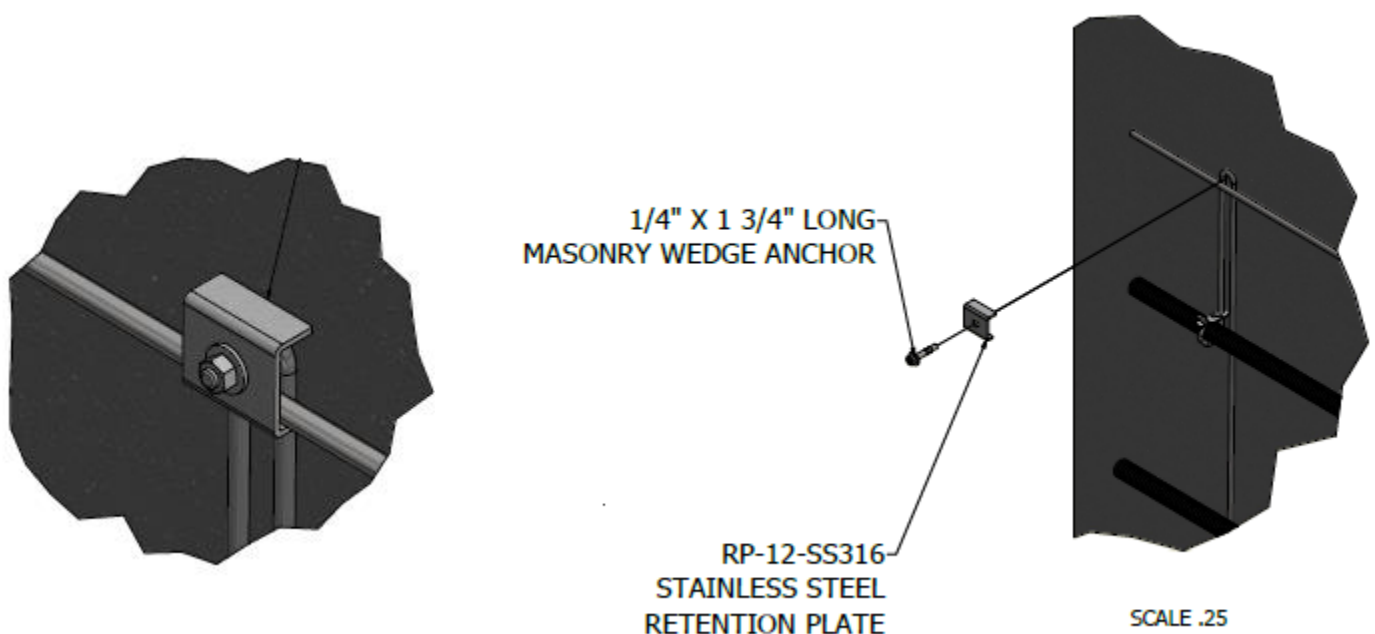

To connect lengths of Snake Tray[®] together use a CB-12-SS316-4 Snake Tray[®] cable support system coupling.

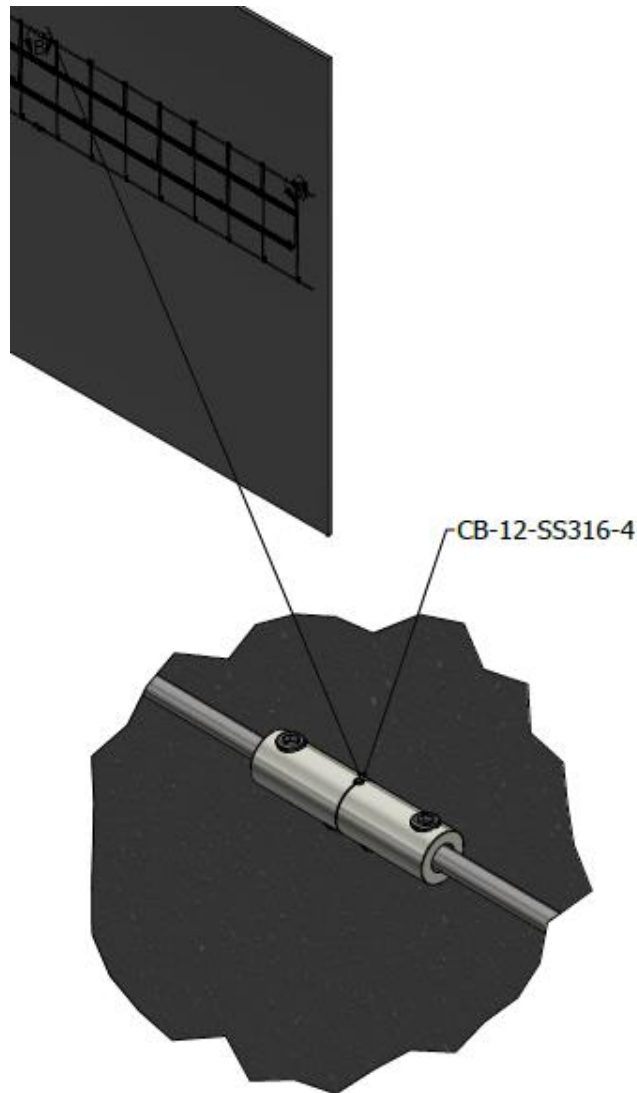

Install the cable along the prescribed pathways. Changes in direction are accomplished by bending the Snake Tray[®] by hand into the desired configurations.

After installation of the Snake Tray[®] on the wall, slide a Retention Clip, PF 505-10-11257, onto the hook. Rest the clip over the hook and insert the armored cable into the hook. The cable should fit snugly into the hook.



Slide the Retention Clip down over the cable and then fasten to the hook portion of the Snake Tray[®].

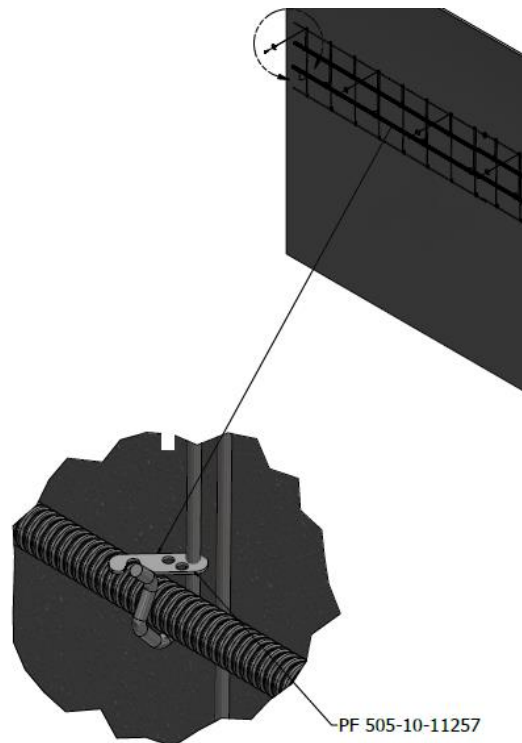

6. ADDITIONAL INFORMATION:

General procedures for terminating are provided below. Be advised that Comtran Cable LLC cannot be responsible for the effectiveness of a termination because we have no control over the fabrication of these items.

The environment should be clean and dry. Tools should be in good working order and used for the purpose that they are designed. Terminating materials must be high quality and be compatible with the cable. Manufacturer instructions for the application of insulating and jacketing materials should be followed.

As shown in the following section, remove the outer jacket (if present) and armor from the end of the cable a sufficient distance to allow separation of the conductors, provide the necessary length to connect to the equipment being used. Any underlying tapes and fillers should then be removed.

- In removing this material, care should be taken not to damage any underlying layer, particularly the cable insulation.
- Install the connector per manufacturer's instructions. Connections to enclosures should be through the use of connectors approved for use with copper armored cable in the particular environment that it is installed.
- Strip the insulation from each conductor for a distance necessary to connect the equipment per the equipment manufacturer's instructions. Care should be taken to avoid cutting, nicking, or scoring of the conductor strands.
- Apply compression terminal lugs or connectors per manufacturer instructions. When using a compression connector, a calibrated, properly sized compression tool should be used.
- Use proper hardware and tightening torque to connect the terminal lugs.

7. JACKET REMOVAL (when provided)

To remove the outer jacket:

1. Measure the length of jacket to be removed and mark. With a sharp knife score around the jacket to about half its thickness. Do not score the armor.
2. Starting at the end of the cable, cut the jacket completely through for the first half inch, continue scoring, but not more than half the thickness of the jacket, back to the score mark.
3. Using pliers, pull the jacket away from the armor starting at the end of the cable and proceed to tear lengthwise along the score mark to the ring score. Remove the jacket.



Armor Removal

1. Mark where the armor is to be cut by wrapping tape around the cable as a guide. Use a tubing cutter to cut the armor. The cutting wheel should be adjusted at the crest of a corrugation and rolled back and forth in ever increasing arcs while advancing the wheel until a 360-degree turn can be made without the tool wobbling off track.
2. If required, mildly flex the cable until the sheath parts at the cut.
3. Slightly rotate sheath back and forth while pulling to remove sheath. Do not rotate completely around. If present filler cord may be entangled. When present, remove tape and filler cord. Remove any burrs. Install the connector according to the connector manufacturer's instructions.

For longer lengths, armor may be removed in sections.



Inner Jacket Removal

1. Mark where jacket is to be cut by wrapping tape around the cable as a guide. Use a knife to longitudinally cut back inner jacket appropriate distance. Leave inner jacket on where possible for additional protection. An adequate length of free conductor should be provided per NEC/CEC. Only cut 50% into jacket. Be careful not to cut insulation.
2. Cut through inner jacket at very end of the cable, then pull apart and peel back inner jacket to end of longitudinal cut.
3. Pull inner jacket up at end of longitudinal cut while cutting in a circular manner. Pull off inner jacket. Inspect insulation for any damage.

